

SCHMEISER® TILL AN' PAK HYDRAULIC TRANSPORT KITS

ASSEMBLY & PARTS MANUAL

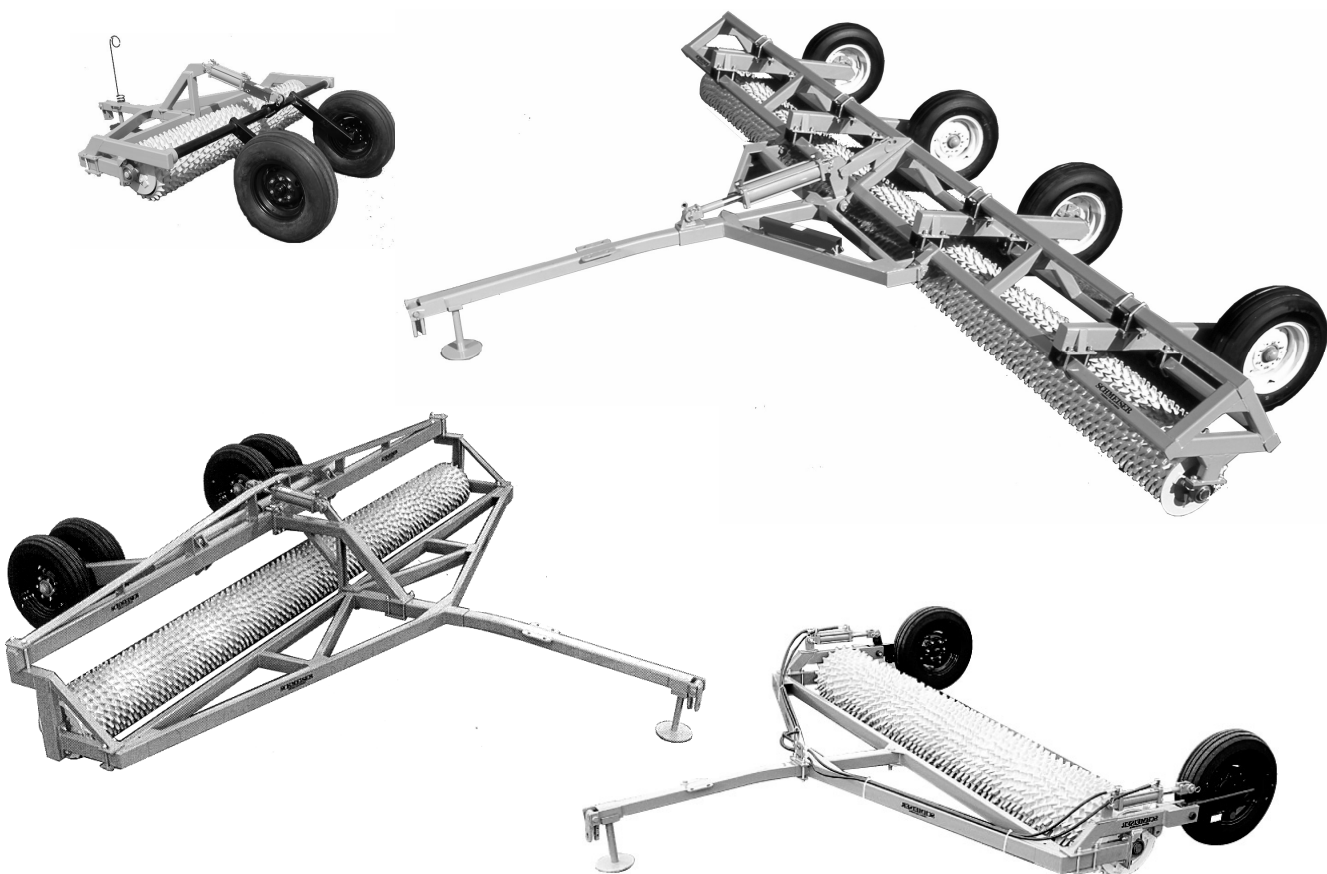

T.G. SCHMEISER CO., INC.
P.O. BOX 1047 FRESNO, CA. 93714
(559) 268-8128 FAX (559) 268-3279
www.tgschmeiser.com

VERSION 1.6a
04-2014

INTRODUCTION

Your Schmeiser Till An' Pak Hydraulic Transport Kit is designed to give you many years of dependable service. This manual has been prepared to instruct you in the safe and efficient operation of this machine. Read and study it thoroughly. Follow all instructions carefully.

Should your Hydraulic Transport Kit require replacement parts, go to your Schmeiser dealer. Always order genuine Schmeiser replacement parts.

If you need information not contained in this manual, contact your Schmeiser dealer.

Space has been provided below for you to record the model number of your Till An' Pak Hydraulic Transport Kit. Be sure to bring this information with you to your dealer when ordering parts for your Hydraulic Transport Kit.

Thank you for buying a Schmeiser Till An' Pak Hydraulic Transport Kit.

MODEL NUMBER _____

DATE PURCHASED _____

DEALER NAME _____

TABLE OF CONTENTS

Introduction.....	2
Table of Contents	3
Till An' Pak Hydraulic Transport Kit Models.....	4
Safety Sheet	5
TPP3510 Transport Kit Assembly	6
TPP3510 Transport Kit Assembly Instructions	7
TPP3520 Transport Kit Assembly	8
TPP3520 Transport Kit Assembly Instructions	9
TPP3530 Transport Kit Assembly	10
TPP3530 Wheel Axle Bearing Assembly	12
TPP3530 Wheel Axle Hub Assembly.....	13
TPP3530 Transport Kit Assembly Instructions	14
TPP3540 Transport Kit Assembly	15
TPP3540 Linkage Assembly.....	16
TPP3540 Wheel Leg Assembly	17
TPP3540 Transport Kit Assembly Instructions	18
Hydraulic Transport Kits Hub Assembly	19
TPP3550 Transport Kit (Straddle Axle) Assembly	20
TPP3550 Wheel Axle Assembly	22
TPP3550 Heavy Duty Wheel Axle Assembly	23
TPP3550 Transport Kit Assembly Instructions	24
Limited Warranty.....	25
Maintenance and Repair Record.....	26
Notes	27

SCHMEISER[®]

HYDRAULIC TRANSPORT KIT

MODELS



TPP3510 – TILL AN' PAKS 2'-0" TO 10'-0"

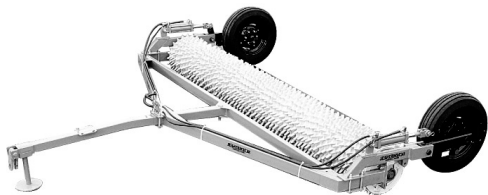

TPP3520 – TILL AN' PAKS 2'-0" TO 14'-0"

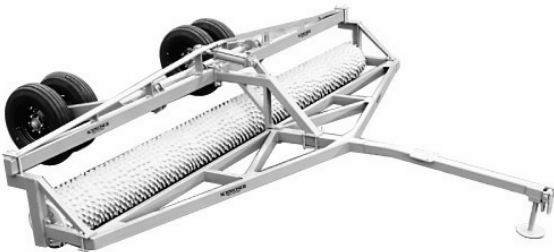

TPP3530 – TILL AN' PAKS 8'-0" TO 24'-0"

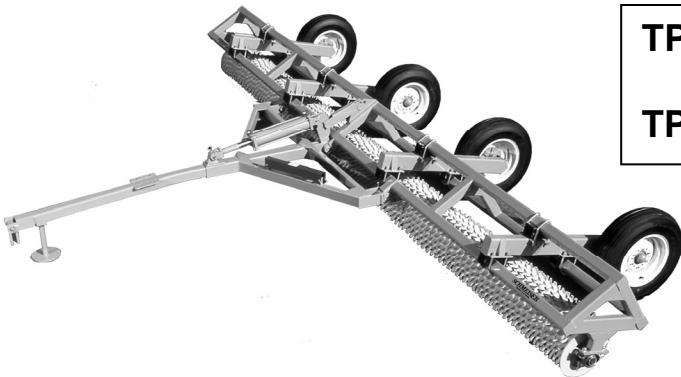

TPP3540 – TILL AN' PAKS 8'-0" TO 24'-0"

TPP3540HD – TILL AN' PAKS 16'-0" TO 24'-0"

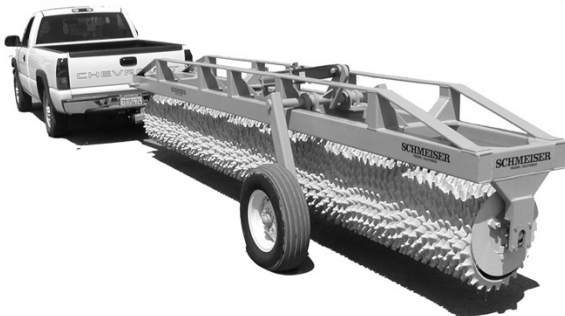

TPP3550 – STRADDLE AXLE -18'-0" TO 30'-0"

SAFETY

The safe operation of any machinery is an important concern to farmers and manufactures. There are obvious and hidden potential hazards involved in the operation of this implement. Carefully read and follow all safety precautions before operation. Serious injury or death may occur unless care is taken to insure the safety of both the operator and any other persons in the area.

1. Never permit anyone to ride on or walk beside the implement when moving.
2. Never permit anyone to ride on tractor when implement is being moved.
3. When performing operating functions, never allow anyone to be near the implement or the tractor.
4. Do not enter tractor when tractor is moving. Avoid serious injury or death from contact with rotating tires. Enter and exit the tractor only when it is completely stopped.
5. Be sure of water, gas, sewer, or electric line locations before operating implement.
6. When in transport, use accessory lights and devices for adequate warning to operators of other vehicles. Comply with all Federal, State and local laws when traveling on public roads.
7. Use “Slow Moving Vehicle” emblem for warning vehicles approaching from the rear.
8. When transporting, remember that the implement may be wider than your tractor and extreme care must be taken to allow for safe clearance.
9. Never allow inexperienced or untrained personnel to operate the implement or tractor without supervision.
10. When using compressed air to clean implement, wear safety glasses.
11. Check all fasteners for tightness or damage before and after operation. Repair immediately if required.
12. Store implement in a stable position. Insure that safety equipment (lockouts, stands, pins, etc.) is secure and in place before detaching from tractor.

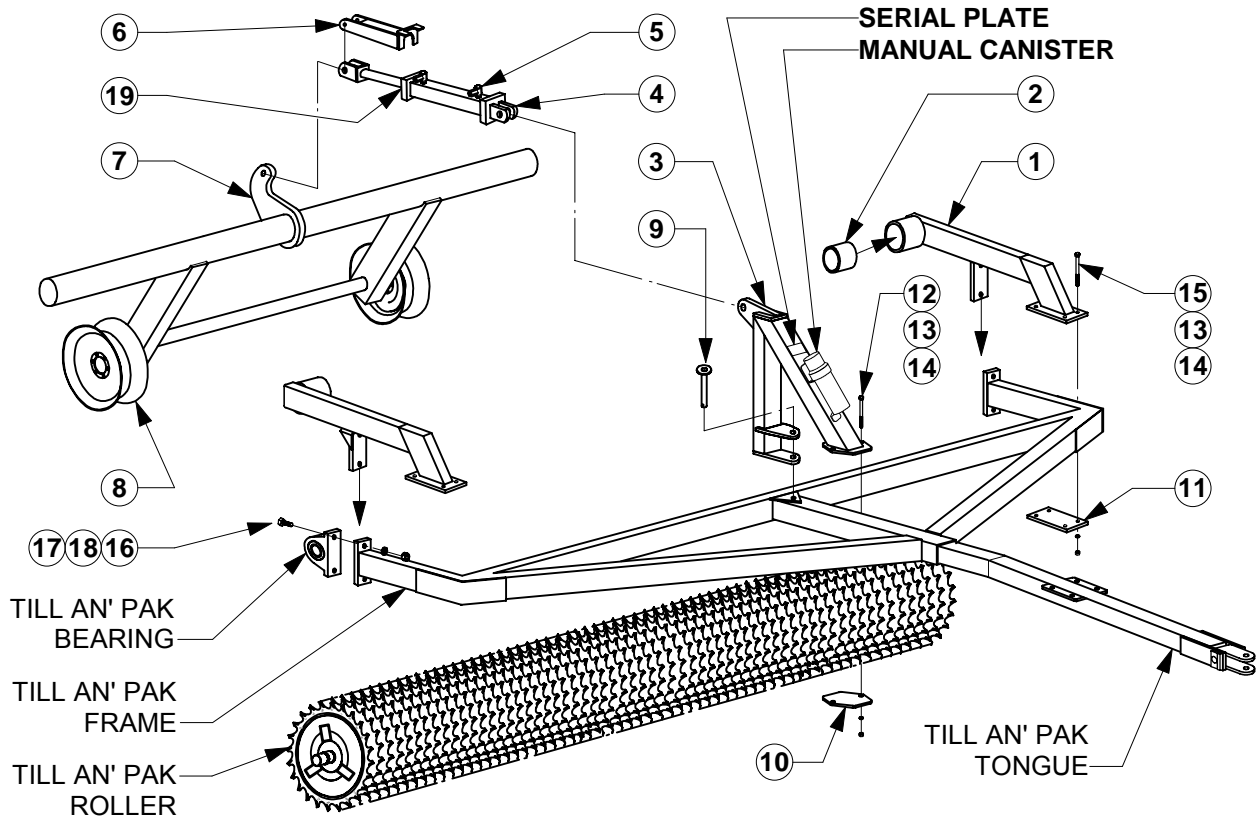

<u>Ref No.</u>	<u>Part No.</u>	<u>Description</u>	<u>Qty.</u>
1.	HT1-00A000L(R)	End Mount Weldment LH (RH)	2
2.	HT1-00C006	Wheel Axle Bearing - UHMW	2
3.	HT1-00B000	Center Frame Weldment	1
4.	GHC-40120T	4" X 12" Tie Rod Hydraulic Cylinder	1
5.	FMBT R9088	1/2" X 1/2" 90-degree Adapters	2
6.	GWD-412LB1	Lockout Bar for 4" X 12" Hyd. Cylinder	1
7.	HT1-(00)C000	Wheel Axle Weldment (specify size)	1
8.	GWT-156LBH	15" X 6" Wheel (See p.19 for Hub Assembly)	2
	GWT-761508	7.6" X 15" Tire with Wheel (Optional)	2
9.	TPP3010	1-1/8" X 6" Tongue Pin Weldment	1
10.	HT1-00B007	Center Frame Front Clamp Plate	1
11.	HT1-00A007	End Mount Bottom Clamp Plate	2
12.	CSNC510088	5/8" X 5-1/2" Gr.5 NC Cap Screw	2
13.	LWASHER-10	5/8" Lock Washer	10
14.	HXNUT-10NC	5/8" NC Hex Nut	10
15.	CSNC510096	5/8" X 6-1/2" Gr.5 NC Cap Screw	8
16.	CSNC508048	1/2" X 3" Gr.5 NC Cap Screw	4
17.	LWASHER-08	1/2" Lock Washer	4
18.	HXNUT-08NC	1/2" NC Hex Nut	4
19.	PMCK-34000	Seal Kit for 4" X 12" Hyd. Cylinder	1



1. Lay Till An' Pak Frame on ground.
2. Unbolt Till An' Pak Frame from Pillow Block Bearings on Roller. Leave Roller attached to Pillow Block Bearings.
3. Position each End Mount (1) between Till An' Pak Frame and Pillow Block Bearing (9).
- Refer to the drawing for positioning.
4. Place Wheel Axle (7) with Plastic Bushings (2) between End Mounts (1). The Cylinder anchor on the Wheel Axle should be facing in the upward position.
5. Bring in End Mounts (1) and install and tighten all fasteners.
- Use (4) 1/2" x 3" Bolts to fasten Pillow Block Bearing, End Mount, and Till An' Pak Frame.
- Use (8) 5/8" x 6" Bolts to attach End Mount to Bottom Clamp Plate (11).
6. Remove Tongue Pin from Till An' Pak Frame. It is located at the base of the Frame tongue guide.
7. Position Center Frame (3) on the tongue guide of the Till An' Pak frame. The two ears at the bottom of the center bracket should slide over the tongue guide pin hole of the Till An' Pak frame. The cylinder anchor portion of the Center Frame should be facing upward at a 45-degree angle aimed toward the rear of the unit. Refer to the drawing for the positioning.
8. Place 1-1/2" x 6-1/2" Tongue Pin in the tongue guide hole. Remember, the tongue, the Center Frame and the tongue guide hole on the frame all have to line up in order to properly install the tongue pin.
- Use (2) 5/8" x 5-1/2" Bolts to attach Center Frame to Front Clamp Plate.
9. Attach 4" x 12" Tie Rod Hydraulic Cylinder (4) to Center Frame and Wheel Axle. The rod clevis of the cylinder should attach to the wheel axle cylinder anchor.
10. Install Cylinder Lockout Bar (4). See drawing for proper installation.
11. Install tires on the wheel axle.

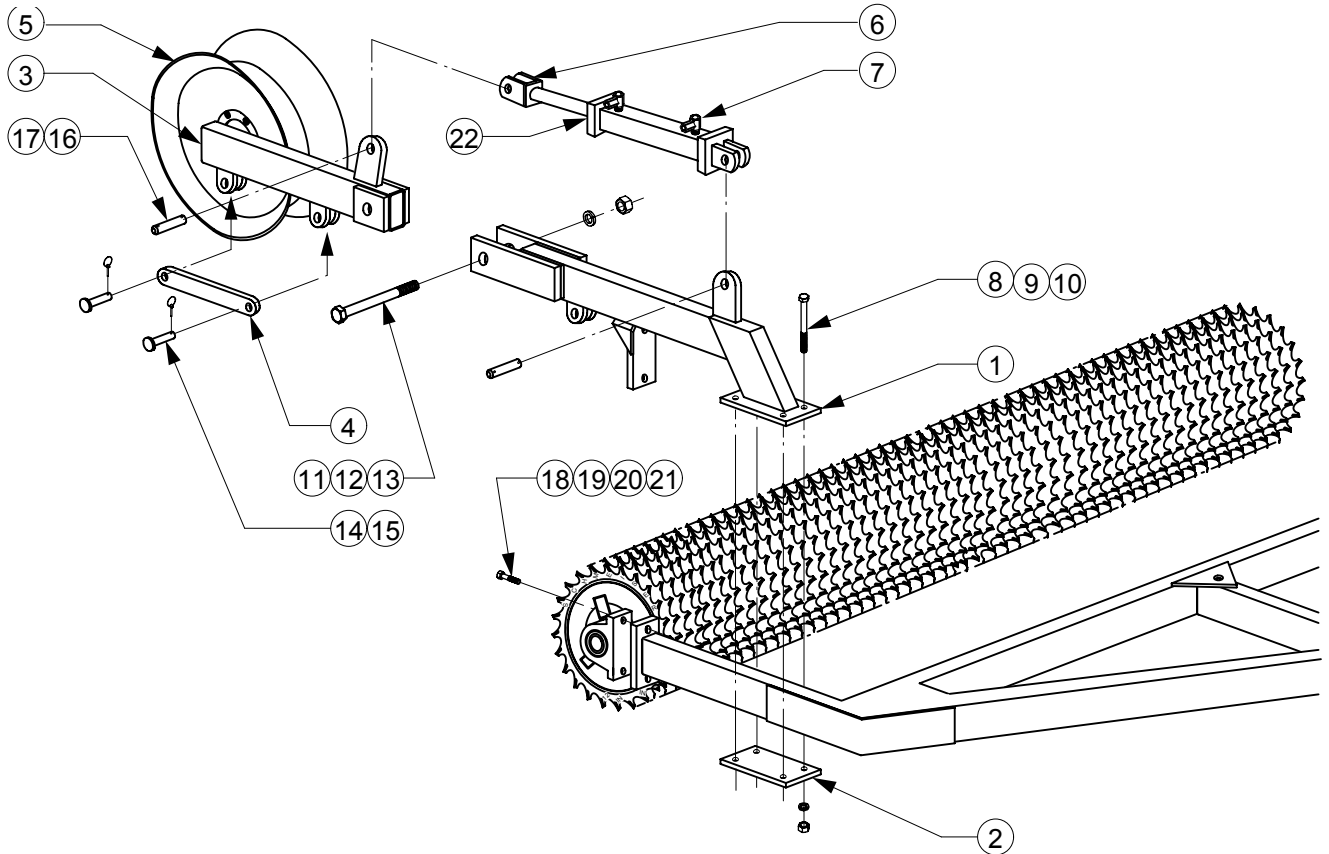

<u>Ref No.</u>	<u>Part No.</u>	<u>Description</u>	<u>Qty.</u>
1.	HT2-00A000L(R)	Till An' Pak Mount Weldment LH or RH	1
2.	HT2-00A007	Bracket Mounting Clamp	2
3.	HT2-00B000L(R)	Tire Axle Leg Weldment LH or RH	1
4.	HT2-00B003	Lockout Plate	2
5.	GWT-156LBH	15 X 6 Wheel Rim (See p.19 for Hub Assembly)	2
	GWT-761508	7.6 X 15 Tire with Wheel (Optional)	2
6.	GHC-25080T	2-1/2" X 8" Tie Rod Hyd. Cylinder	2
7.	FMBT R9086	1/2" M ^o - 3/8" T R90 Fitting	4
8.	CSNC510096	5/8" X 6" NC Cap Screw Gr.5	10
9.	LWASHER-10	5/8" Lock Washer	10
10.	HXNUT-10NC	5/8" NC Hex Nut	10
11.	CSNC818096	1-1/8" X 6" NC Cap Screw Gr.8	2
12.	LWASHER-18	1-1/8" Lock Washer	2
13.	HXNUT-18NC	1-1/8" NC Hex Nut	2
14.	GPN-12X040	3/4" X 2-1/2" Clevis Pin	4
15.	GPN-040LYN	1/4" Lynch Pin	4
16.	GPN-1656HC	1" X 3-1/2" Cylinder Pin	4
17.	GPN-03CLIP	5/32" Wire Dia. Hair Pin Clip	8
18.	CSNC508048	1/2" X 3" Gr.5 Cap Screw	4
19.	LWASHER-08	1/2" Lock Washer	4
20.	HXNUT-08NC	1/2" NC Hex Nut	4
21.	FWASHER-08	1/2" Flat Washer	4



1. Lay Till An' Pak Frame on ground.
2. Unbolt Till An' Pak Frame from Pillow Block Bearings on Roller. Do not remove Pillow Block Bearings from Roller.
3. Position each End Bracket (1) with attached Tire Axle Leg (3) between Till An' Pak Frame and Pillow Block Bearing.
 - Be sure to properly place left side and right side End Brackets in place. Refer to the drawing for positioning.
 - Use (4) 1/2" x 3" Bolts to fasten Pillow Block Bearings with Roller attached, End Brackets with Tire Axle Legs attached, and Till An' Pak Frame.All fasteners - hand tighten only!
4. Position Hydraulic Cylinder (6) with rod side facing toward wheel. Attach cylinder side with Cylinder Pin (16). Next, position other end of Cylinder same way (Note: Elevation of wheel may be necessary in order to align holes.)
5. Position Hydraulic Hose Manifold on tongue guide, with fittings facing toward rear of unit. Manifold distance is adjustable. (Not shown on picture)
6. Connect retract and extend hoses to "T" fitting, then all lead hoses to tractor.
7. Securely tighten all fasteners.

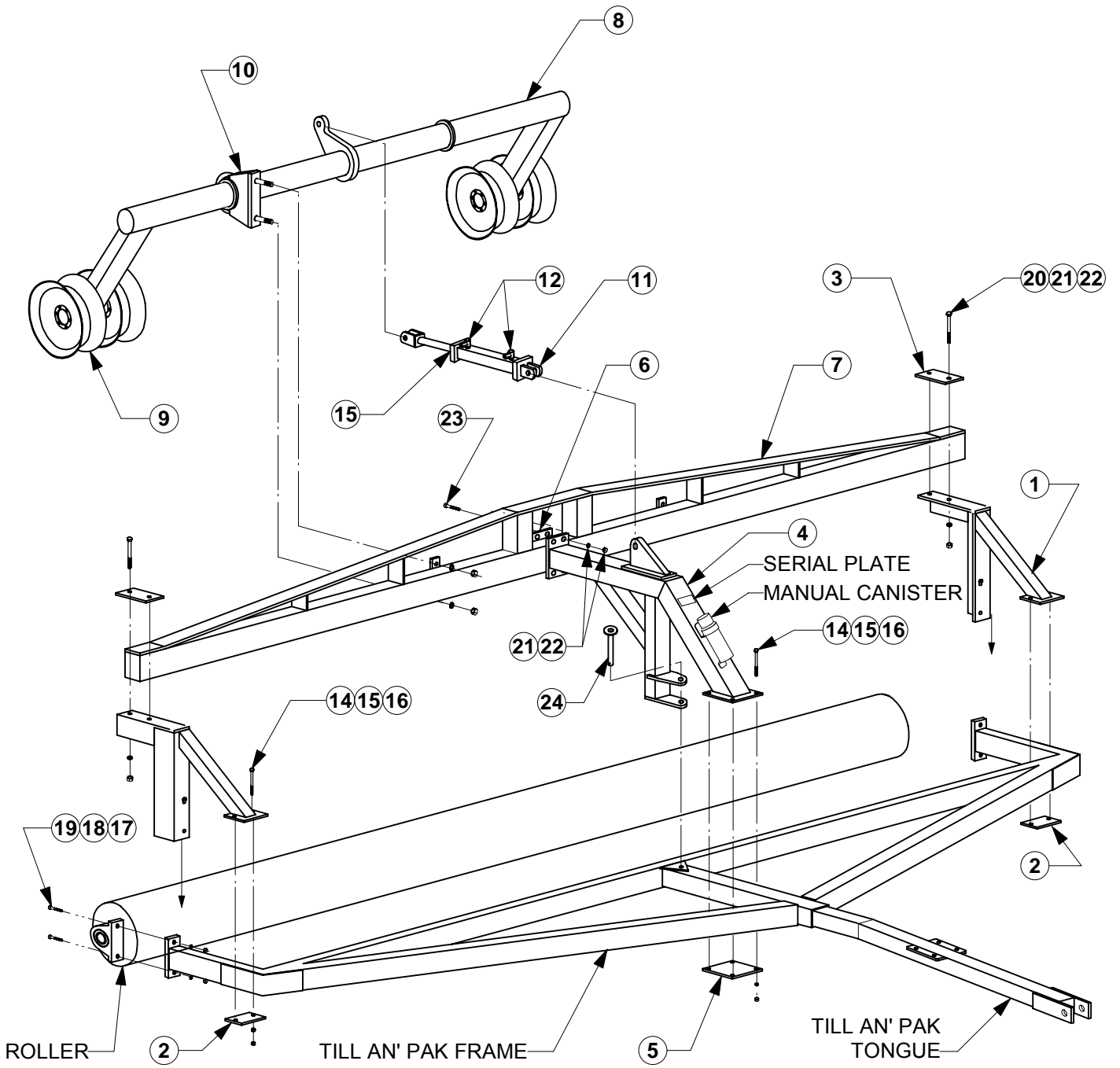



<u>Ref No.</u>	<u>Part No.</u>	<u>Description</u>	<u>Qty.</u>
1.	HT3-00B000L(R)	End Bracket Weldment LH (RH)	2
2.	HT3-00B005	End Bracket to Frame Clamp Plate	2
3.	HT3-00B006	End Bracket to Cross Bar Clamp Plate	2
4.	HT3-00A000	Center Bracket	1
5.	HT3-00A007	Center Bracket to Frame Clamp Plate	1
6.	HT3-00A008	Center Bracket to Cross Bar Clamp Plate	1
7.	HT3-(00)D000	Main Bar Weldment (specify size)	1
8.	HT3-00C000	Wheel Axle Weldment	1
9.	GWT-156LBH	15 X 6 Wheel (see p.19 for Hub Assembly)	4
	GWT-761508	7.6 X 15 Tire with Wheel (Optional)	4
10.	SLL1353	Wheel Axle Bearing Assembly (See p.12 for details)	2
11.	GHC-35100T	3-1/2" x 10" Tie Rod Hydraulic Cyl.	1
12.	FMBT R9088	1/2" X 1/2" 90-degree Adapters	2
13.	PMCK-33500	Seal Kit for 3-1/2" x 10" Hyd. Cylinder	1
14.	CSNC510096	5/8" X 6" Gr.5 NC Cap Screw	8
15.	LWASHER-10	5/8" Lock Washer	8
16.	HXNUT-10NC	5/8" NC Hex Nut	8
17.	CSNC508048	1/2" X 3" Gr.5 NC Cap Screw (15 ft. and under)	4
	CSNC510048	5/8" X 3" Gr.5 NC Cap Screw (16 ft. and up)	4
18.	LWASHER-08	1/2" Lock Washer (15 ft. and under)	4
	LWASHER-10	5/8" Lock Washer (16 ft. and up)	4
19.	HXNUT-08NC	1/2" NC Hex Nut (15 ft. and under)	4
	HXNUT-10NC	5/8" NC Hex Nut (16 ft. and up)	4
20.	CSNC512120	3/4" X 7-1/2" Gr.5 NC Cap Screw	4
21.	LWASHER-12	3/4" Lock Washer	8
22.	HXNUT-12NC	3/4" NC Hex Nut	8
23.	CSNC512080	3/4" X 5" Gr.5 NC Cap Screw	4
24.	GPN-18X104	1-1/8" X 6-1/2" Pin Weldment	1



WHEEL AXLE BEARING ASSEMBLY

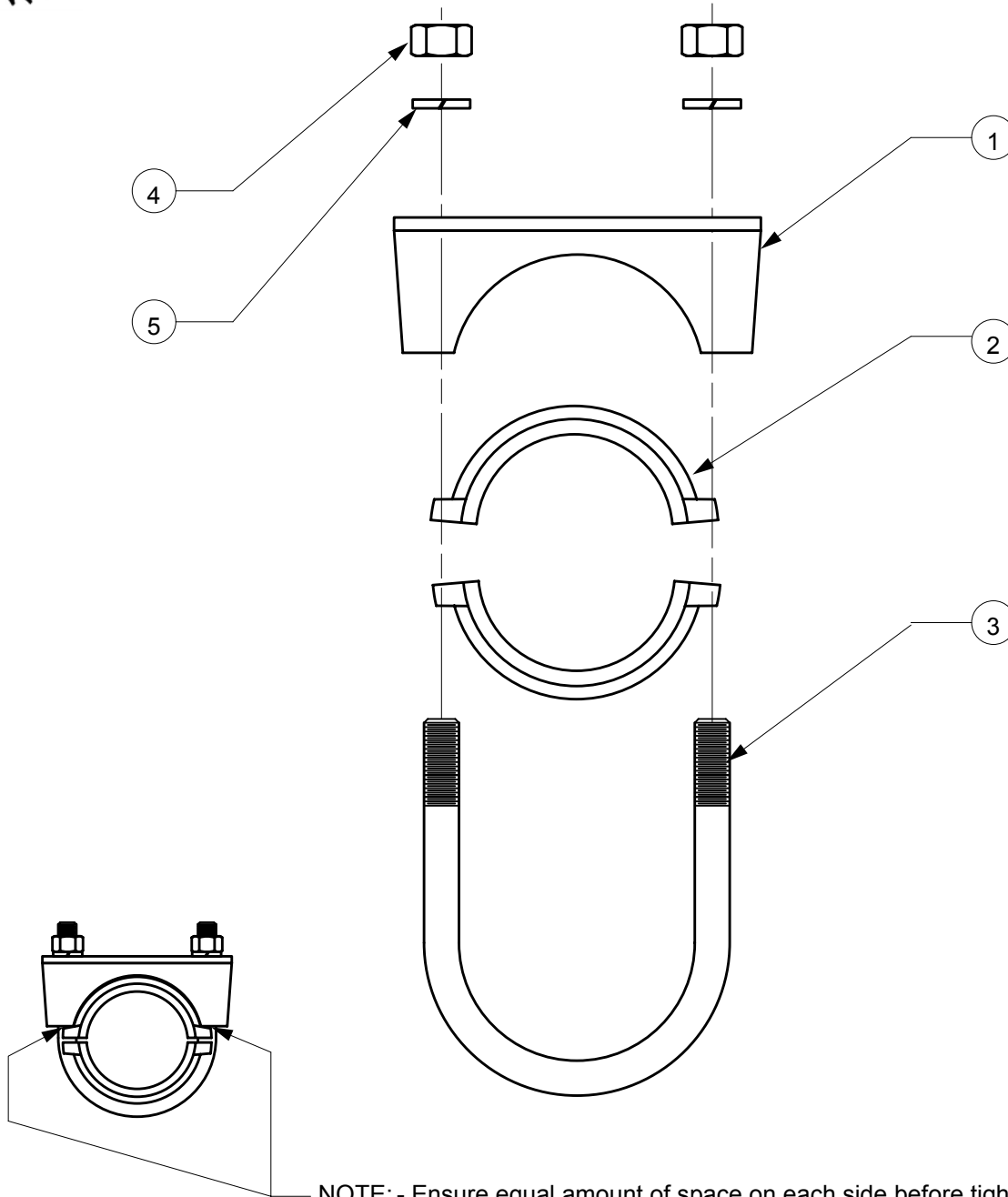

NOTE: - Ensure equal amount of space on each side before tightening U-Bolt.
 - Ensure equal number of threads on each side of U-Bolt.

<u>Ref No.</u>	<u>Part No.</u>	<u>Description</u>	<u>Qty.</u>
1.	SLL 1351	Bearing Cradle Cap Weldment	4
2.	SLL 1350	Bearing Cap Casting Machined	8
3.	UBNC16122R	1" Bearing U-bolt	4
4.	HXNUT-16NC	1" NC Hex Nut	8
5.	LWASHER-16	1" Lock Washer	8
	SLL 1352	U-Bolt Assembly (includes items 3, 4, and 5)	
	SLL 1353	Axle Bearing Assembly (includes items 1, 2, 3, 4, and 5)	

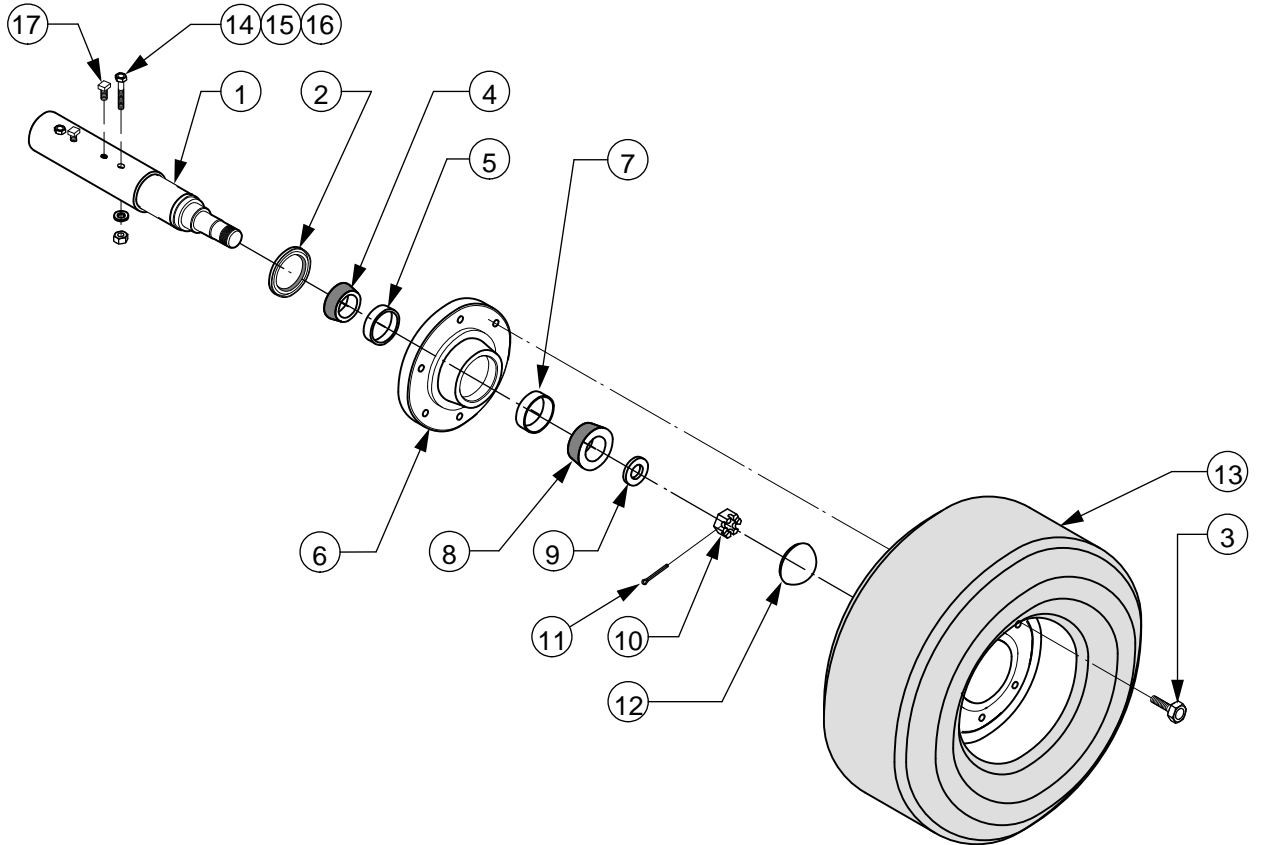

Ref No.	Part No.	Description	Quantity	
			2-Wheel Option	4-Wheel Option
1.	HT3-00C200	2" x 14" Removable Single Ended Spindle	2	-
	TBU-01G016	2" x 20-1/4" Removable Double Ended Spindle	-	2
2.	GHB-6X6GSL	Grease Seal	2	4
3.	WHB-08X016	1/2" x 1" UNF Wheel Bolts for 6 on 6 Std. Hub	12	24
4.	GHB-6X6ICN	Inner Bearing Cone for 6 on 6 Std. Hub	2	4
5.	GHB-6X6IRC	Inner Bearing Cup for 6 on 6 Std. Hub	2	4
6.	GHB-6X6STD	Standard 6 on 6 Hub Assembly Complete (includes items 2, 3, 4, 5, 7, 8, 12)	2	4
7.	GHB-6X6ORC	Outer Bearing Cup for 6 on 6 Std. Hub	2	4
8.	GHB-6X6OCN	Outer Bearing Cone for 6 on 6 Std. Hub	2	4
9.	GSP-14SPWA	Spindle Washer	2	4
10.	GSP-14CANT	Spindle Castle Nut	2	4
11.	GPN-03X032C	3/16" x 2" Cotter Pin	2	4
12.	GHB-6X6CAP	Hub Cap	2	4
13.	GWT-156LBH	15 x 6 Wheel - Standard	2	4
	GWT-761508	7.6 x 15 8 Ply Tire with Wheel - Optional	2	4
14.	CSNC507056	7/16" x 3-1/2" Gr.5 NC Cap Screw	4	4
15.	LWASHER-07	7/16" Lock Washer	4	4
16.	HXNUT-07NC	7/16" NC Hex Nut	4	4
17.	SSNCS08X16	1/2" x 1" Set Screw	4	4



1. Lay Till An' Pak Frame on ground.
2. Unbolt Till An' Pak Frame from Pillow Block Bearings on Roller. Do not remove Pillow Block Bearings from Roller.
3. Position each End Bracket (1) between Till An' Pak Frame and Pillow Block Bearing.
 - Be sure that the angle iron leg of the End Bracket points inward. Refer to the drawing for positioning.
 - Use (4) 1/2" x 3" or (4) 5/8" x 3" Bolts to fasten Pillow Block Bearing, End Bracket, and Till An' Pak Frame.
 - Use (4) 5/8" x 6" Bolts to attach End Bracket - Roller Frame Mount Plate.All fasteners - hand tighten only!
4. Remove Tongue Pin from Till An' Pak Frame. It is located at the base of the Frame tongue guide.
5. Position Center Bracket (4) on the tongue guide of the Till An' Pak frame. The two ears at the bottom of the center bracket should slide over the tongue guide pin hole of the Till An' Pak frame. The cylinder anchor portion of the Center Bracket should be facing upward at a 45-degree angle aimed toward the rear of the unit. Refer to the drawing for the positioning.
 - Place 1-1/2" x 6-1/2" Tongue Pin in the tongue guide hole. Remember, the tongue, the Center Bracket and the tongue guide hole on the frame all have to line up in order to properly install the tongue pin.
 - Use (4) 5/8" x 6" Bolts to attach Center Bracket - Roller Frame Mount Plate.All fasteners - hand tighten only!
6. Position Main Cross Bar (7) on top of the End Bracket. The bar should be placed between the two holes on the topside of the End Bracket. The truss strap should be positioned on the top and the two sets of the Bearing Mount Plates welded on the Main Cross Bar should be placed to the back side of the machine.
 - Use (4) 3/4" x 5" Bolts to attach Center Bracket - Main Cross Bar Mount Plate.
 - Use (4) 3/4" x 7-1/2" Bolts to attach Main Cross Bar - End Bracket Mount Plate.All fasteners - hand tighten only!
7. Attach Wheel Axle (8) to Main Cross Bar (7) using the Bearing Assemblies. The Cylinder anchor on the Wheel Axle should be facing in the upward position.
8. Attach 3-1/2" x 10" Hydraulic Cylinder (13) to Center Bracket and Wheel Axle. The rod clevis of the cylinder should attach to the wheel axle cylinder anchor.
9. Securely tighten all fasteners.



1-CYLINDER UNIT

2-CYLINDER UNIT (HEAVY DUTY)

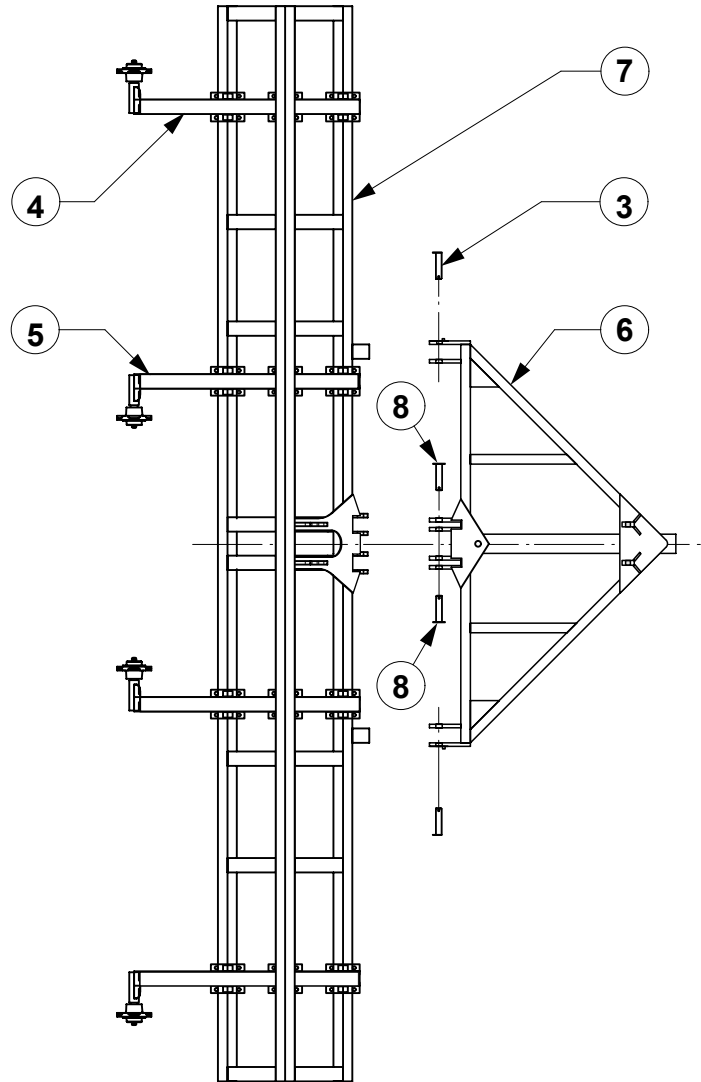
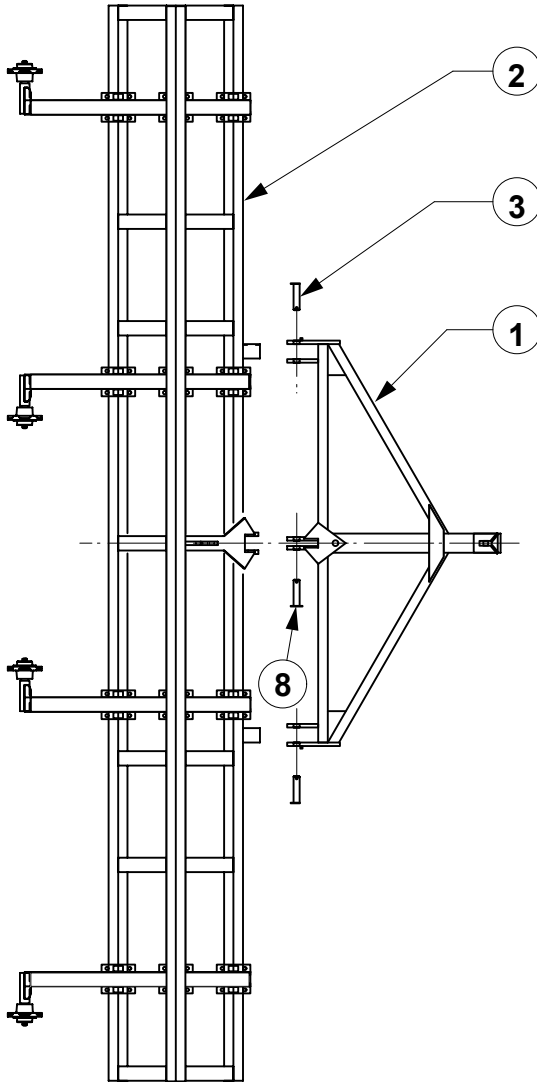

<u>Ref No.</u>	<u>Part No.</u>	<u>Description</u>	<u>Qty.</u>
1.	HT4-00A100	Pull Frame for 1-Cyl. Units	1
2.	HT4-(00)B100	Main Frame for 1-Cyl. Units (specify size)	1
3.	HT4-00A008	Pull Frame Pin	2
4.	HT4-00D000L	Axle Leg with Hub, Left	1
5.	HT4-00D000R	Axle Leg with Hub, Right	1
6.	HT4-00A200	Pull Frame for 2-Cyl. Units	1
7.	HT4-(00)B200	Main Frame for 2-Cyl. Units (specify size)	1
8.	GPN-20CA03	1-1/4" X 5-1/2" Pin	1 or 2

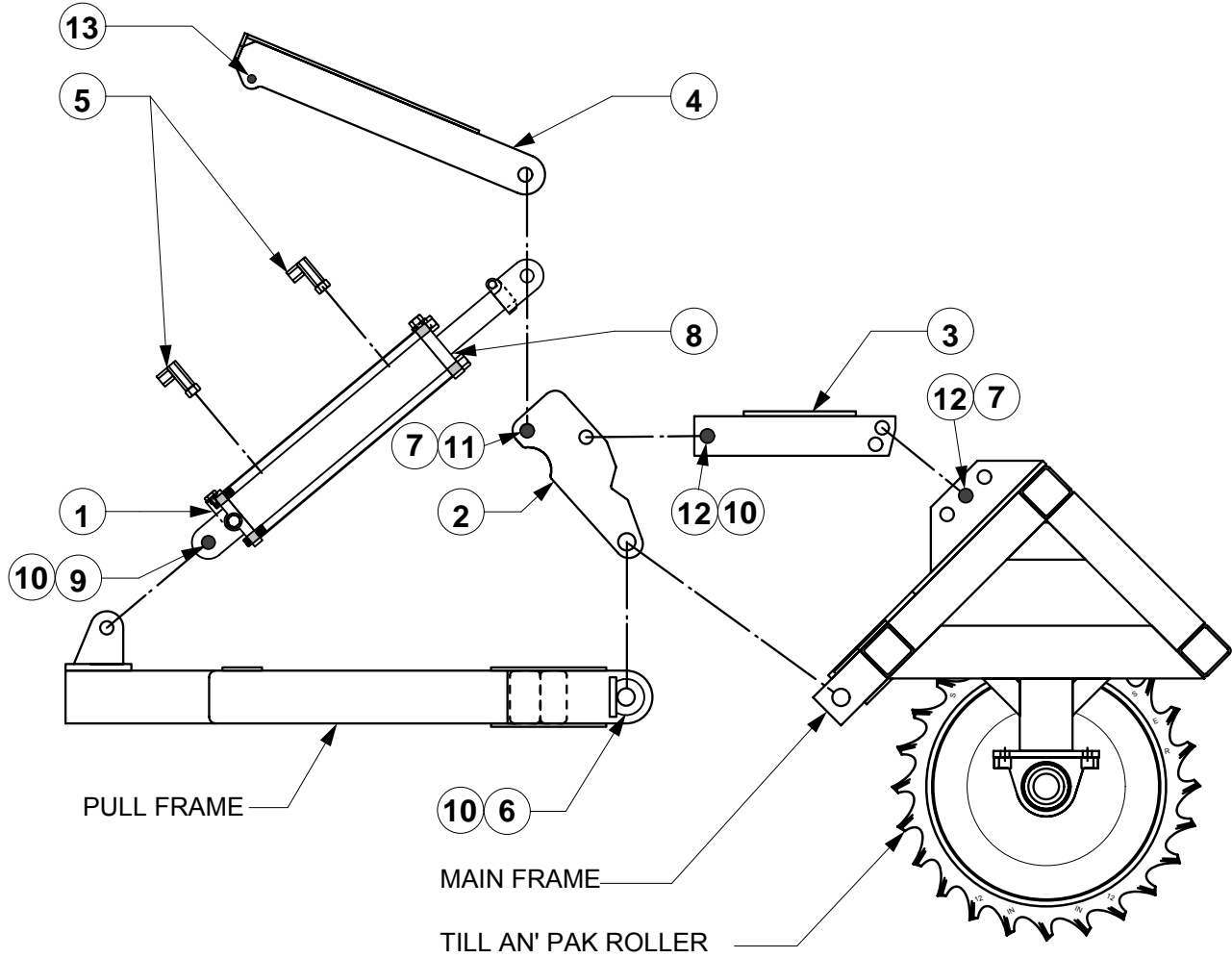

Ref No.	Part No.	Description	Qty.	
			1-Cyl.	2-Cyl.
1.	GHC-40160T	4" X 16" Tie Rod Hydraulic Cylinder	1	2
2.	HT4-00C003	Hydraulic Cylinder Linkage Pivot Plate	1	2
3.	HT4-00C000	Hydraulic Cylinder Linkage Weldment	1	2
4.	GWD-416LB1	Lockout Bar for 4" X 16" Hydraulic Cylinder	1	2
5.	FMBT R9088	1/2" X 1/2" 90 degree Adapters	2	4
6.	HT4-00A008	Pull Frame Pin	3	4
7.	GPN-040LYN	1/4" Lynch Pin	3	4
8.	PMCK-34000	Seal Kit for 4" X 16" Hydraulic Cylinder	1	2
9.	GPN-1664HC	1" X 4" Cylinder Pin	1	2
10.	GPN-04X40C	1/4" Cotter Pin	6	8
11.	GPN-16X068	1" X 4-1/2" Std. Clevis Pin (red)	1	2
12.	GPN-16X040	1" X 2-1/2" Std. Clevis Pin	1	2
13.	GPN-0856SL	1/2" X 3-1/2" Lockout Bar Pin	1	2

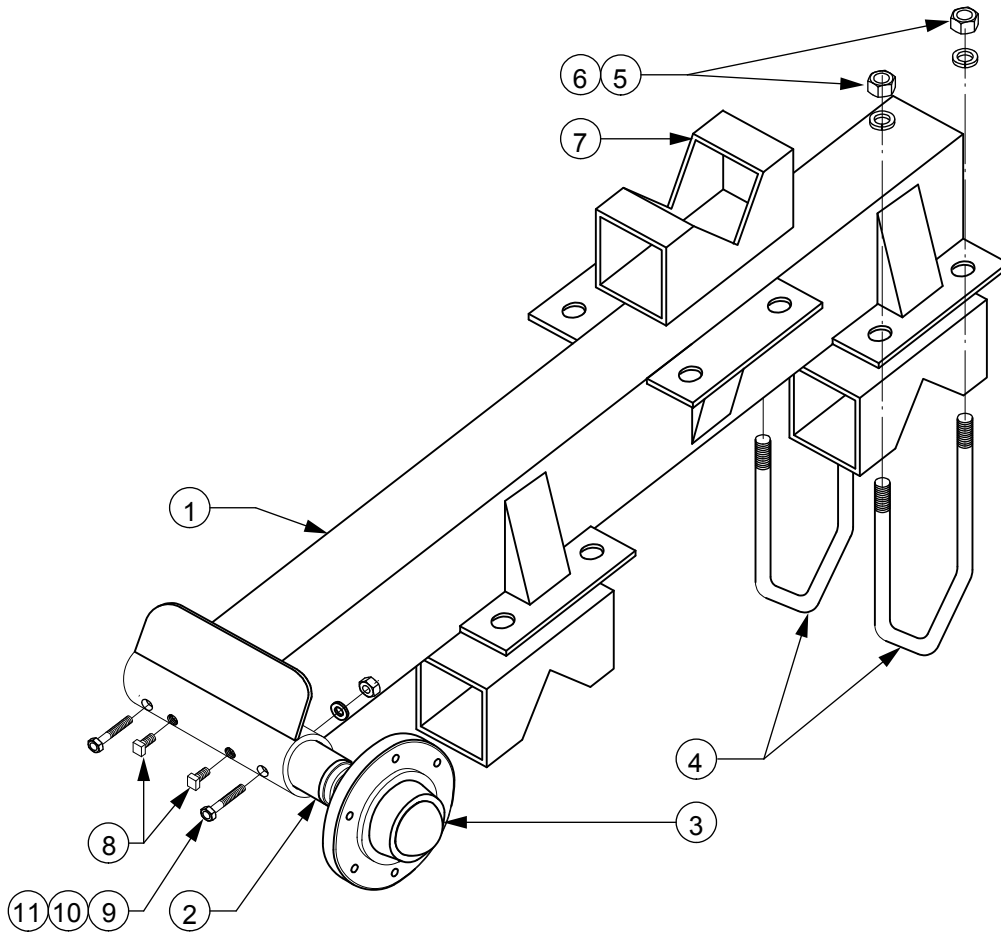

<u>Ref No.</u>	<u>Part No.</u>	<u>Description</u>	<u>Qty. per Leg</u>
1.	HT4-00D000	Wheel Axle Leg	1
2.	HT3-00C200	2" x 14" Single Ended Removable Spindle	1
3.	GHB-6X6STD	6 on 6 Hub Complete (see p.19 for Hub Assembly)	1
4.	UBNC10X66T	5/8" NC Tri Bend U-Bolt	6
5.	HXNUT-10	5/8" NC Hex Nut	12
6.	LWASHER-10	5/8" Lock Washer	12
7.	HT4-00D006	Wheel Axle Leg Spacer	3
8.	SSNCS08X16	1/2" X 1" NC Set Screw	2
9.	CSNC507056	7/16" X 3-1/2" NC Cap Screw	2
10.	LWASHER-07	7/16" Lock Washer	2
11.	HXNUT-07NC	7/16" NC Hex Nut	2



1. Lay Till An' Pak Roller on ground. Position Main Frame over Roller and bolt frame to Pillow Block Bearings.
- Use (4) 1/2" x 2-1/4" Gr.5 NC Bolts (14 ft. to 18 ft. units) or 5/8" x 2-1/2" Gr.5 NC bolts (19 ft. & up units.)
2. Position Wheel Leg between the bottom cross bars and top cross bar with wheel facing outward (saddle mounting plates on bottom of wheel axle should face downward.)
3. Place saddle pads under wheel axle on two bottom cross bars (see Wheel Leg Assembly drawing on page 16).
4. Position Wheel Leg to desired distance from side end of unit (spacing of wheel is based upon customer's needs.)
5. Position third saddle between top cross bar and Wheel Leg. Tilt Wheel Leg and place into position (use of a mallet hammer may be necessary.)
6. Fasten Wheel Leg with two Tri-Bend U-Bolts on each mount.
Same procedure is required for center Wheel Leg (wheels face inward, opposite direction of end wheels.)
7. Mount tires to Wheel Legs and tighten (Tires are optional).
8. Fasten outer set of ears of Pull Frame to the Main Frame (1-1/4" x 5-1/2" yellow Pin and 1/4" Cotter Pin.) After fastening be sure to grease both zerks holes (see Assembly drawing on page 14.)
9. Position Pivot Plate between Main Frame center ears and fasten with 1-1/4" x 5-1/2" yellow Clevis Pin (refer to the drawing on page 15 for proper positioning).
10. Slide Pull Frame in front of Main Frame. Position 1-1/8" x 6-1/2" Tongue Pin in Pull Frame tongue hole.
11. Position Hydraulic Cylinder with rod facing toward rear of unit. Align holes with Pivot Plate and lockout bar (elevation of Pull Frame may be necessary.)
- Use 1" x 4-1/2" Red Clevis Pin with 1/4" Lynch Pn.
12. Remove plugs from cylinder before extending.
13. Thread in place (2) 90-degree adapters into cylinder.
14. Check tightness of all bolts and make sure all pins are in place.

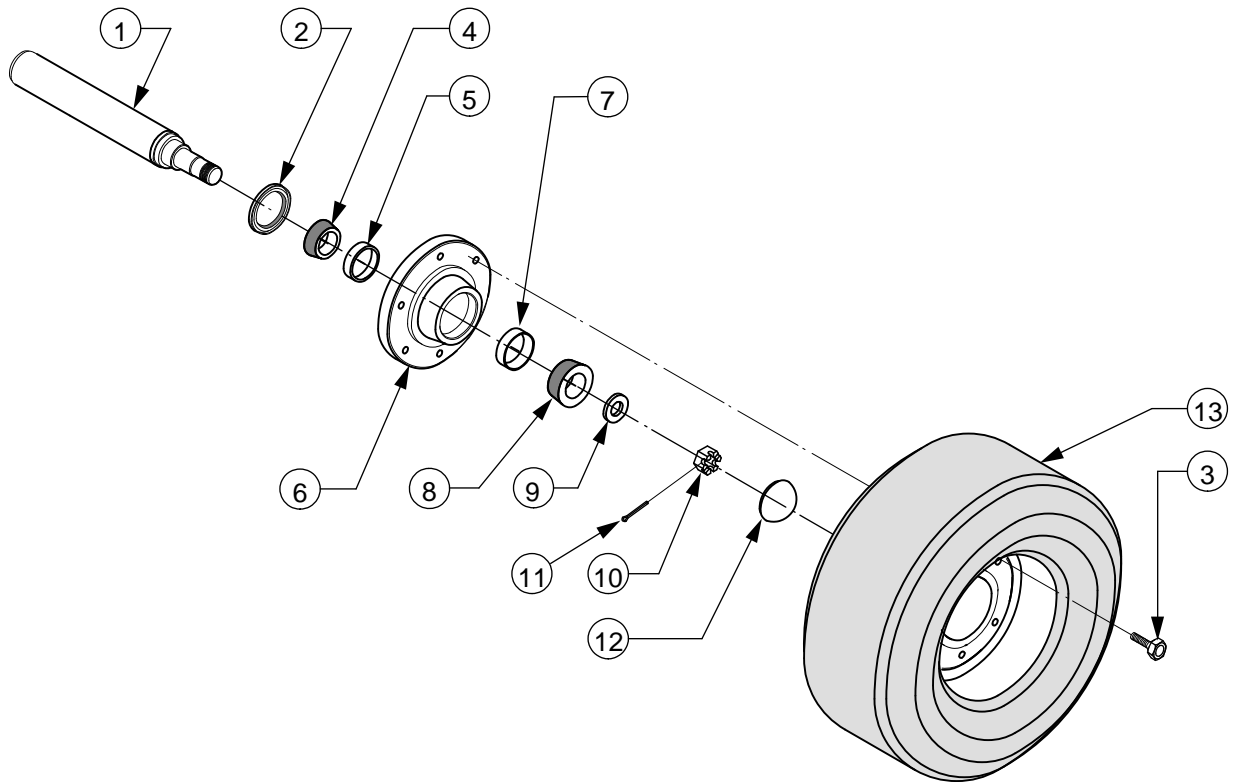

Ref No.	Part No.	Description	Quantity per spindle	
			TPP3510	TPP3520
1.	GSP-32176S	2" x 11" Single Ended Spindle	1	1
2.	GHB-6X6GSL	Grease Seal	1	1
3.	WHB-08X016	1/2" x 1" UNF Wheel Bolts for 6 on 6 Std. Hub	6	6
4.	GHB-6X6ICN	Inner Bearing Cone for 6 on 6 Std. Hub	1	1
5.	GHB-6X6IRC	Inner Bearing Cup for 6 on 6 Std. Hub	1	1
6.	GHB-6X6STD	Standard 6 on 6 Hub Assembly Complete (includes items 2, 3, 4, 5, 7, 8, 12)	1	1
7.	GHB-6X6ORC	Outer Bearing Cup for 6 on 6 Std. Hub	1	1
8.	GHB-6X6OCN	Outer Bearing Cone for 6 on 6 Std. Hub	1	1
9.	GSP-14SPWA	Spindle Washer	1	1
10.	GSP-14CANT	Spindle Castle Nut	1	1
11.	GPN-03X032C	3/16" x 2" Cotter Pin	1	1
12.	GHB-6X6CAP	Hub Cap	1	1
13.	GWT-156LBH	15 X 6 Wheel - Standard	1	1
	GWT-761508	7.6 x 15 8 Ply Tire with Wheel - Optional	1	1

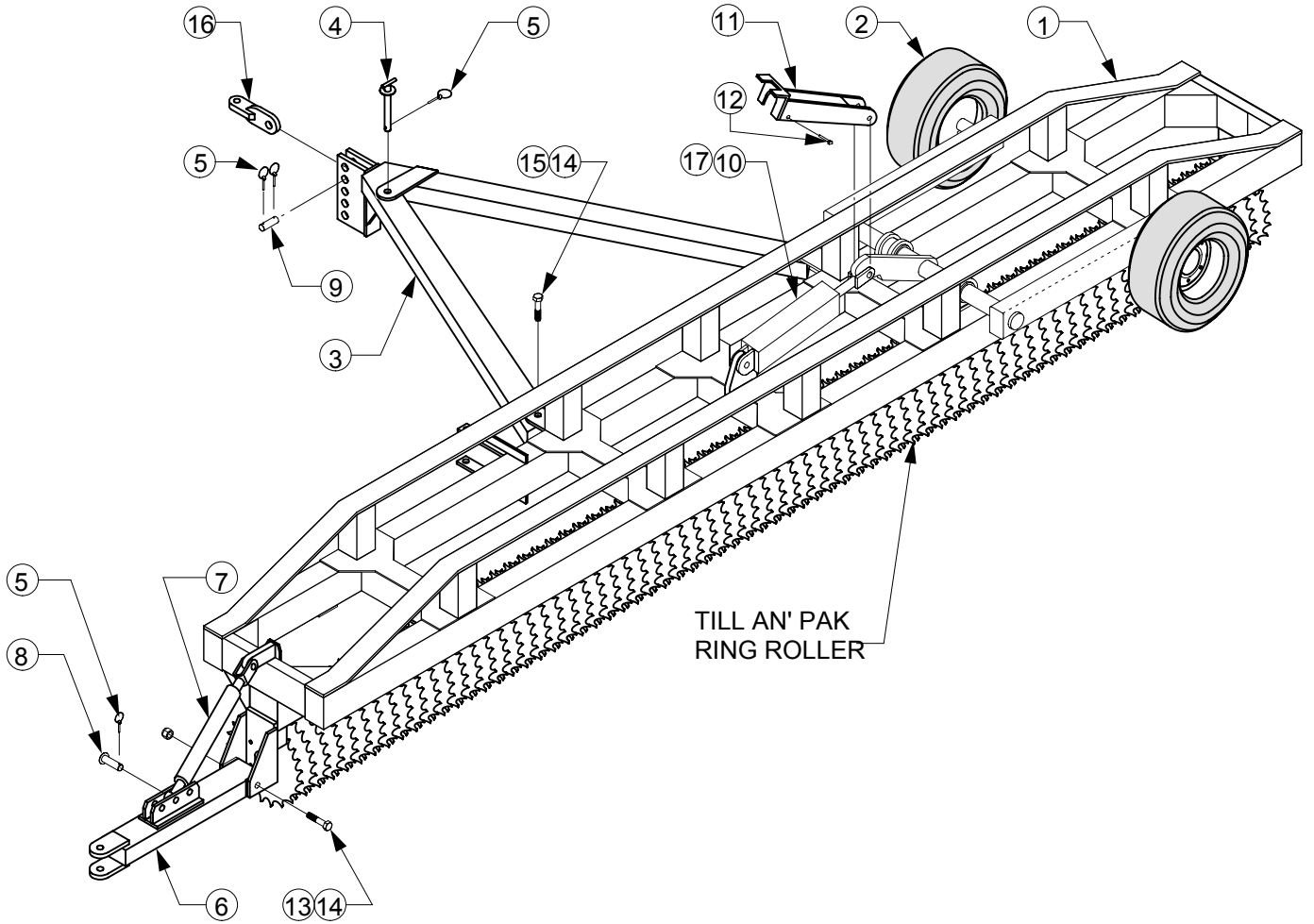



<u>Ref No.</u>	<u>Part No.</u>	<u>Description</u>	<u>Qty.</u>
1.	TSA-(00)A000	Straddle Axle Main Frame Weldment (specify size)	1
2.	TSA-00C000	Wheel Axle Weldment	1
	TSA-00C100	Heavy Duty Wheel Axle Weldment	1
3.	TSA-(00)D000	Pull Frame Assembly (specify size)	1
4.	GPN-16112L	1" X 7" General Lock Pin Weldment	1
5.	GPN-040LYN	1/4" Lynch Pin	1
6.	TSA-00E000	Straddle Axle Tongue Weldment	1
7.	TSA-00G000	Straddle Axle Ratchet Weldment	1
8.	GPN-16X048	1" X 3" Standard Clevis Pin Weldment	2
9.	TSA-00F003	Straddle Axle Tongue Pin	1
10.	GHC-40160T	4" X 16" Tie Rod Hydraulic Cylinder	1
11.	GWD-416LB2	Lockout Bar for 4" X 16" Hydraulic Cylinder SA	1
12.	GPN-0856SL	1/2" X 3-1/2" Swivel Lock Pin	1
13.	CSNC816144	1" X 9" Gr.8 NC Cap Screw	1
14.	NYNUT-16NC	1" NC Hex Nylon Lock Nut	4
15.	CSNC516128	1" X 8" Gr.5 NC Cap Screw	2
16.	FTP-00C000	FTP Pull Frame Hitch Clevis Weldment	1
17.	PMCK-34000	Seal Kit for 4" X 16" Hydraulic Cylinder	1

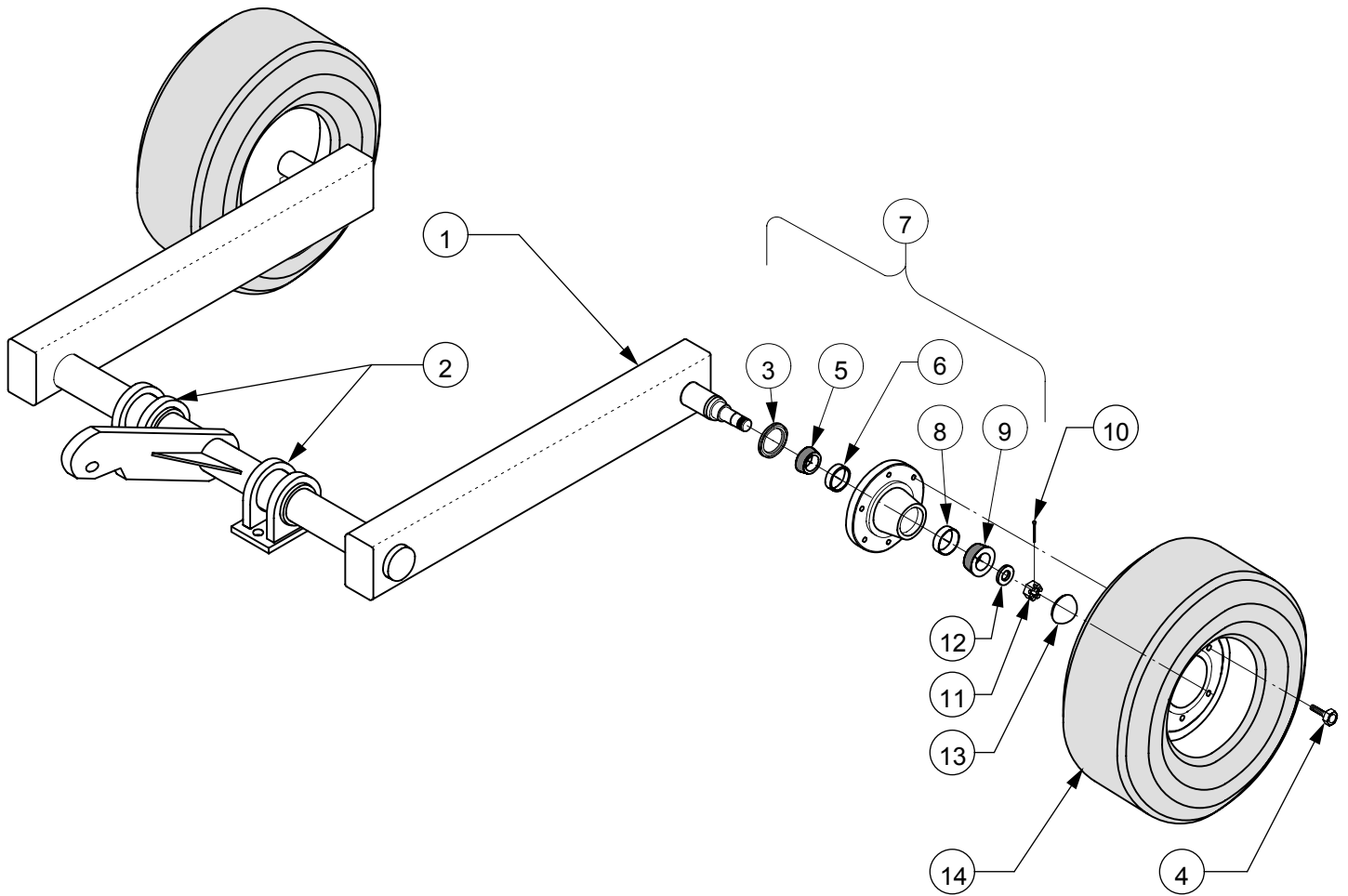

<u>Ref No.</u>	<u>Part No.</u>	<u>Description</u>	<u>Qty.</u>
1.	TSA-00C000	Wheel Axle Weldment	1
2.	TSA-00B000	Wheel Axle Bearing Weldment	2
3.	GHB-6X6GSL	Grease Seal	2
4.	WHB-08X016	1/2" x 1" UNF Wheel Bolts for 6 on 6 Std. Hub	12
5.	GHB-6X6ICN	Inner Bearing Cone for 6 on 6 Std. Hub	2
6.	GHB-6X6IRC	Inner Bearing Cup for 6 on 6 Std. Hub	2
7.	GHB-6X6STD	Standard 6 on 6 Hub Assembly Complete (includes items 3, 4, 5, 6, 8, 9, 13)	2
8.	GHB-6X6ORC	Outer Bearing Cup for 6 on 6 Std. Hub	2
9.	GHB-6X6OCN	Outer Bearing Cone for 6 on 6 Std. Hub	2
10.	GSP-14SPWA	Spindle Washer	2
11.	GSP-14CANT	Spindle Castle Nut	2
12.	GPN-03X32C	3/16" x 2" Cotter Pin	2
13.	GHB-6X6CAP	Hub Cap	2
14.	GWT-951508	9.5 x 15 8 Ply Tire with Wheel	2

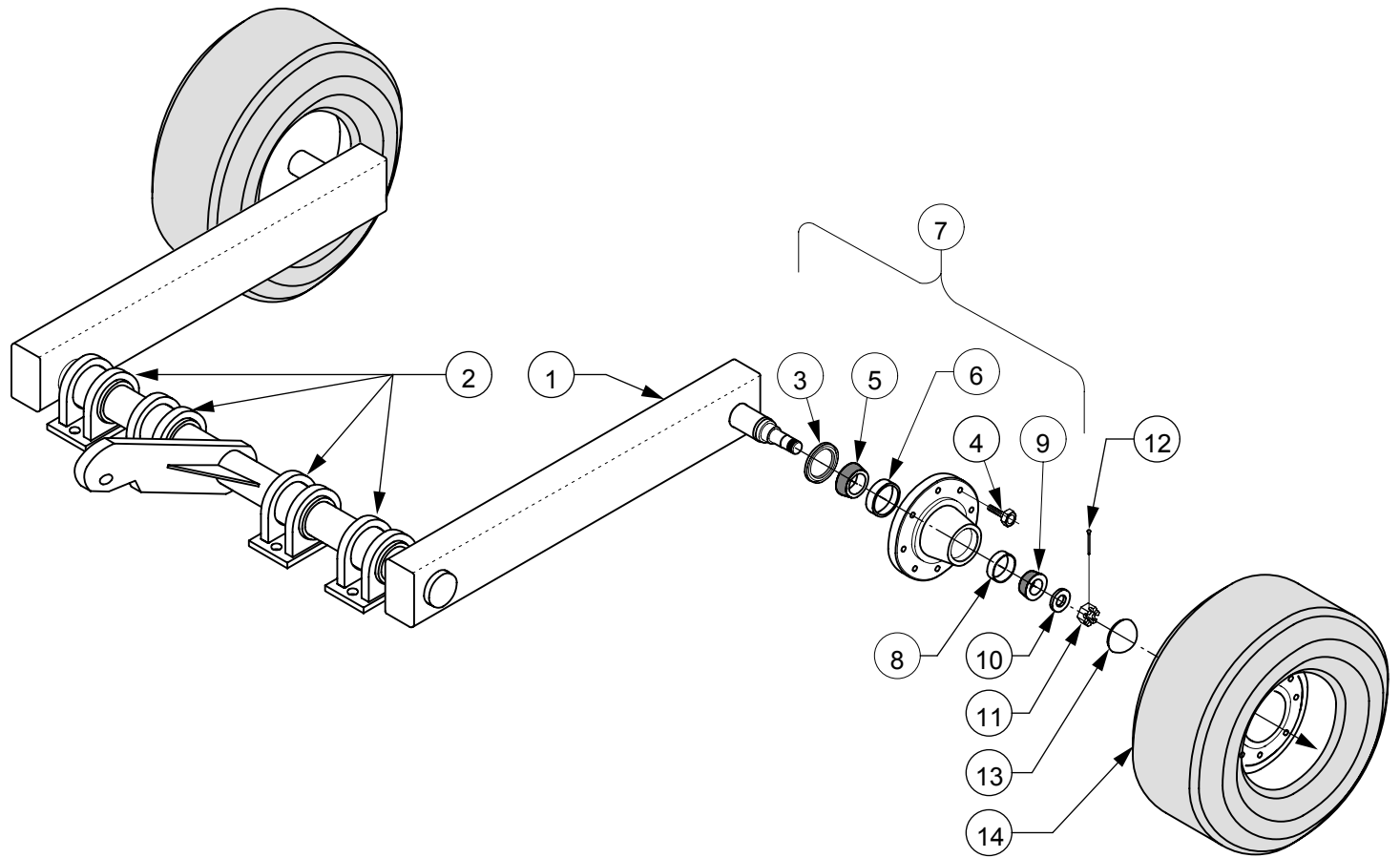

<u>Ref No.</u>	<u>Part No.</u>	<u>Description</u>	<u>Qty.</u>
1.	TSA-00C100	Heavy Duty Wheel Axle Weldment	1
2.	TSA-00B000	Wheel Axle Bearing Weldment	4
3.	GHB-8X8GSL	Grease Seal	2
4.	WHB-09X018	Wheel Bolts for 8 on 8 Heavy Hub	16
5.	GHB-8X8ICN	Inner Bearing Cone for 8 on 8 Heavy Hub	2
6.	GHB-8X8IRC	Inner Bearing Cup for 8 on 8 Heavy Hub	2
7.	GHB-8X8HVY	Heavy 8 on 8 Hub Assembly Complete (includes items 3, 4, 5, 6, 8, 9, 13)	2
8.	GHB-8X8ORC	Outer Bearing Cup for 8 on 8 Heavy Hub	2
9.	GHB-8X8OCN	Outer Bearing Cone for 8 on 8 Heavy Hub	2
10.	GSP-14SPWA	7/8" Spindle Flat Washer	2
11.	GSP-14CANT	7/8" NF Spindle Castle Nut	2
12.	GPN-03X32C	3/16" x 2" Cotter Pin	2
13.	GHB-8X8CAP	Hub Cap	2
14.	GWT-121614	12.5 x 16 14 Ply Tire with Wheel	2



1. Lay Till An' Pak Roller on ground. Install flange bearings of ring roller shafts.
2. Position Main Frame over Roller and bolt frame and roller to flange bearings.
 - Use (4) 5/8" x 2-1/2" Gr.5 NC bolts with lock washers and hex nuts.
3. Install Wheel Axle to Main Frame. Tighten wheel axle bearings onto main frame bearing mounts.
 - Use 3/4" x 2" Gr.5 NC bolts with lock washers and hex nuts.
4. Install tire and wheel assemblies onto hubs on the wheel axle. Refer to page 22 (standard duty) or 23 (heavy duty) for details.
5. Mount Pull Frame large brace (with clevis attached) to the main frame, then mount secondary brace to the main frame.
 - Use 1" x 8" Gr.5 NC bolts with nylon lock nuts.Connect to each other for field use with lock pin. See drawing on page 20 for reference.
For transport, remove lock pin and swing both braces forward onto storage plate and secure with same lock pin.
6. Install transport tongue. Fasten with 1" x 9" Gr.8 NC bolt and 1" nylon lock hex nut.
7. Install Ratchet weldment. Bushing side - to the tongue, clevis side - to main frame.
 - Use 1" x 3" standard clevis pin with lynch pin on tongue side and cylinder pin with cotter pins on main frame side.
8. Mount 4" x 16" Hydraulic cylinder to Main Frame and then to Wheel Axle. Install Lockout Bar. Refer to assembly drawing on page 20 for details.
9. Install Jack Stand to front of Main Frame.

T.G. SCHMEISER CO., INC.®

Limited Warranty Statement

T. G. Schmeiser Co., Inc. warrants each new Schmeiser® product to be free from defects in material and workmanship. This warranty is applicable only for the normal service life expectancy of the product or components, not to exceed twelve (12) consecutive months from the date of delivery of the new Schmeiser product to the original purchaser.

Genuine T. G. Schmeiser Co., Inc. replacement parts and components will be warranted for 90 days from date of purchase, or the remainder of the original equipment warranty period, whichever is longer.

Under no circumstances will it cover any merchandise or components thereof, which, in the opinion of the company, has been subjected to misuse, unauthorized modifications, alteration, an accident or if repairs have been made with parts other than those obtainable through T. G. Schmeiser Co., Inc.

The Company in no way warrants engines, batteries, cylinders, tires or other trade accessories since these items are warranted separately by their respective manufacturer. Expendable components such as points, shanks, blades, rings, bearings, teeth, and the like are excluded from this warranty.

Our obligation under this warranty shall be limited to repairing or replacing, free of charge to the original purchaser, any part that, in our judgment, shall show evidence of such defect, provided further that such part shall be returned within thirty (30) days from date of failure to T. G. Schmeiser Co., Inc., routed through the dealer and distributor from whom the purchase was made, transportation charges prepaid.

This warranty shall not be interpreted to render T. G. Schmeiser Co., Inc. liable for injury or damages of any kind or nature to person or property. This warranty does not extend to the loss of crops, loss because of delay in harvesting, or any expense or loss incurred for labor, substitute machinery, rental or for any other reason.

Except as set forth above, **T. G. Schmeiser Co., Inc. shall have no obligation or liability of any kind on account of any of its equipment and shall not be liable for special or consequential damages. T. G. Schmeiser Co., Inc. makes no other warranty, expressed or implied, and, specifically, T. G. Schmeiser Co., Inc. disclaims any implied warranty or merchantability or fitness for a particular purpose. Some states or provinces do not permit limitations or exclusions of implied warranties or incidental or consequential damages, so the limitations or exclusion in this warranty may not apply.**

This warranty is subject to any existing conditions of supply, which may directly affect our ability to obtain materials or manufacture replacement parts.

T. G. Schmeiser Co., Inc. reserves the right to make improvements in design or changes in specifications at any time, without incurring any obligation to owners of units previously sold.

No one is authorized to alter, modify or enlarge this warranty nor the exclusion, limitations and reservations.

**WARRANTY VOID IF NOT REGISTERED
WITHIN 30 DAYS OF PURCHASE DATE**

Notes

A large rectangular box with a black border, containing 18 horizontal gray bars. The bars are arranged in a repeating pattern of a gray bar followed by a white bar, starting from the top and ending with a gray bar at the bottom. This layout is intended for taking notes.

Notes

A large rectangular box with a black border, containing 15 horizontal gray bars for writing notes. The bars are arranged in a repeating pattern of gray and white, providing a structured space for taking notes.